

Three-color Illumination AOI Series

Features

- The angles of red/green/blue/white color LED beads can be customized.
- Each color beads can be designed to be controlled separately.

Applications

- PCB soldering inspection (applied to inspecting missing/wrong / inclined parts, insufficient/excessive/ no soldering, and other defects in PCB industry).
- Surface defects inspection for multiple layers.

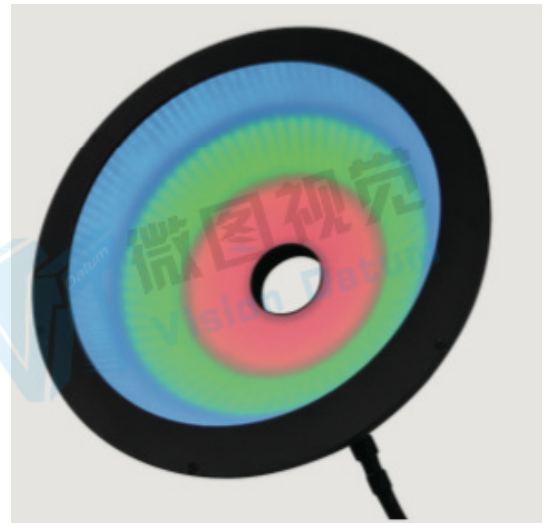

Examples of AOI Light Images

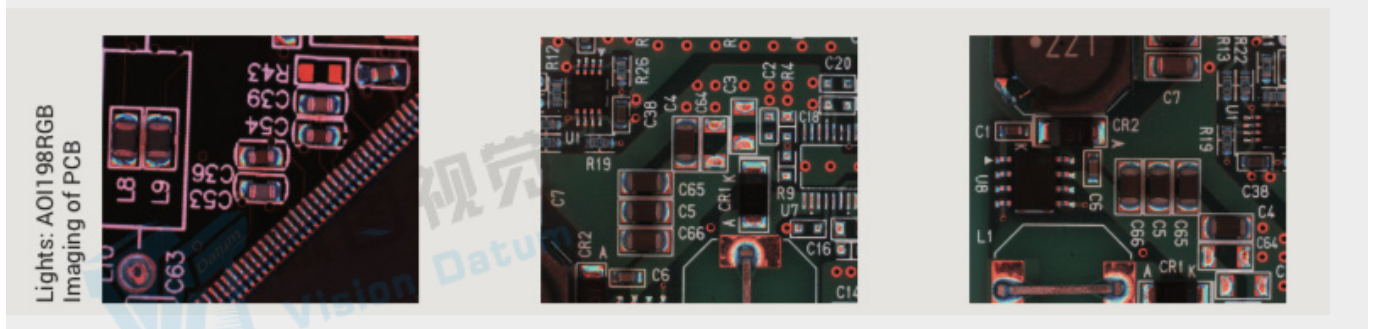

Model No.	Voltage (v)	Power cons. (w)	Dimensions		
			Outer diam. (mm)	Inner diam. (mm)	Height (mm)
VT-AOI120RGB	24	18	120	40	52
VT-AOI150RGB	24	25	150	74	75
VT-AOI180RGB	24	48.7	180	45	68
VT-AOI210RGB	24	48.7	210	66	74.6

Dimension (mm)

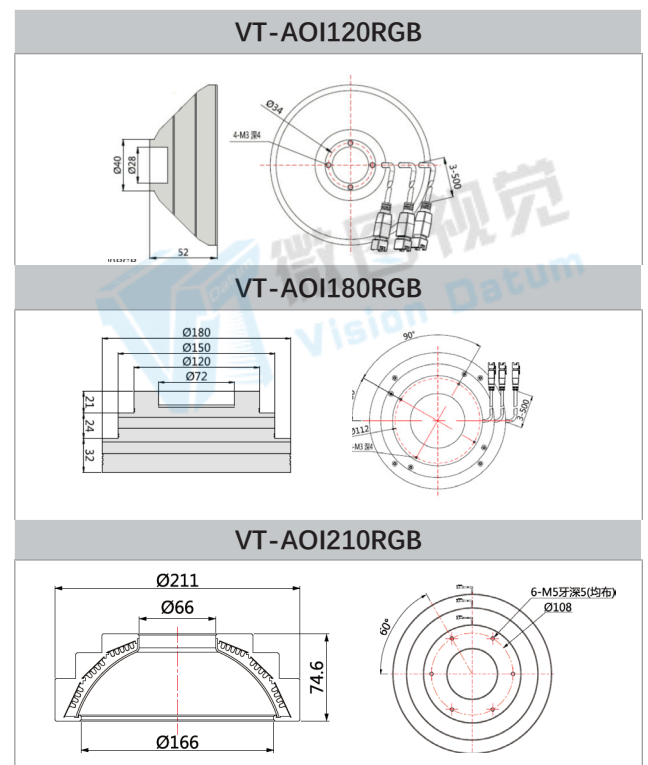

Lighting Structure

