

Coaxial Illumination -C Series

Features

- High density LED provide high brightness light ray.
- Highly-accurate optical glass is used for the camera window and spectroscope.

Applications

- Inspection of high reflective surface scratches, defects of chip and silicon wafer, etc..
- Mark point position, laser character detection, bar code recognition

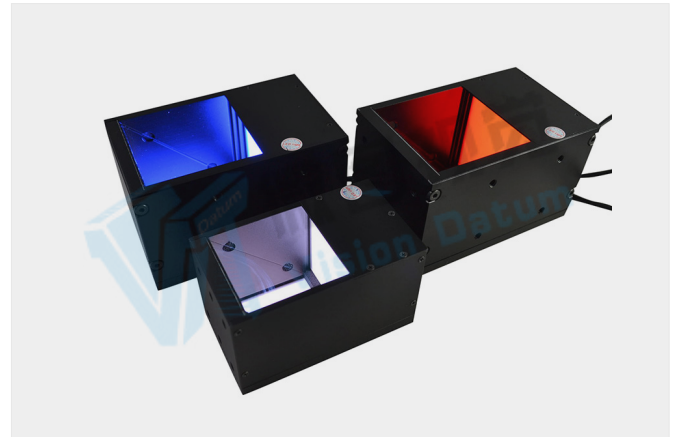

Examples of Coaxial Light Images

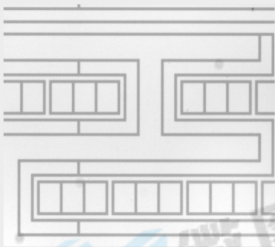

Lights: C40UV405

Checking ITO circuit in the touch screen with the new coaxial UV lighting, High brightness and uniformity.

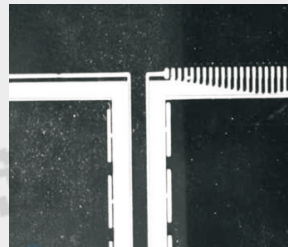

Lights: C20R

Touch screen position alignment system

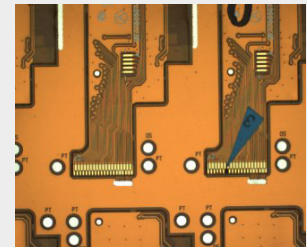

Lights: C50B

Checking the completeness of pins in FPC

Explanation of Model Code

VT-LT2-C	19	19	(W/B/G/R)
Series	Emitting Length	Emitting Width	Color

Common Specifications

Input voltage	24 VDC
Connector	SMR-03V-B
Wavelength range	Red: 620-630nm; Blue: 460-475nm; Green: 520-530nm;
Color temperature (white)	5800-7500K
Operating environment (indoor)	Temperature: 0~40°C Humidity: 20% to 85% RH (with no condensation)
Life time	White:30,000hrs, Red: 60,000hrs (Depends on the operating environment, not a guarantee)
Case material	Aluminum alloy, Resin

Illumination Structure

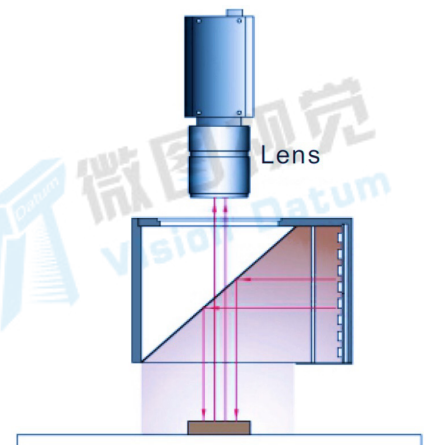

Model No.	Optical spec.		Electrical specifications (GREEN / NIR / UV Accept custom)			Dimensions		
	Length (mm)	Width (mm)	Supply Voltage (v)	Power cons. (w) ●	Power cons. (w) ● ○ ●	Length (mm)	Width (mm)	Height (mm)
VT-LT2-C2020	20	20	24	2.2	2.1	64	31	27
VT-LT2-C3030	30	30	24	1.8	2.5	74	40	37
VT-LT2-C4038	40	38	24	2.7	3.3	52	50	47
VT-LT2-C4040	40	40	24	2.7	3.7	86	50	47
VT-LT2-C5050	50	50	24	5.3	6.1	96	60	57
VT-LT2-C6060	60	60	24	7.2	9.8	106	70	67
VT-LT2-C7573	75	73	24	10.1	12.0	120	85.4	79
VT-LT2-C8583	85	83	24	13.2	17.1	130	95.4	89
VT-LT2-C100100	100	100	24	17.7	26.8	146	110	107
VT-LT2-C120120	120	120	24	21.2	27.0	166	130	127
VT-LT2-C150120	150	120	24	22.5	20.7	166	160	127
VT-LT2-C200180	200	180	24	24.2	25.2	310	212	187

Dimension (mm)

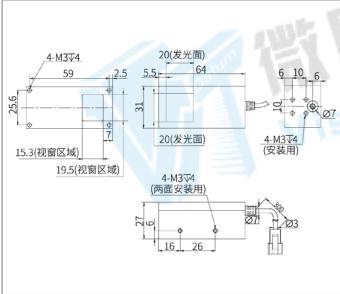
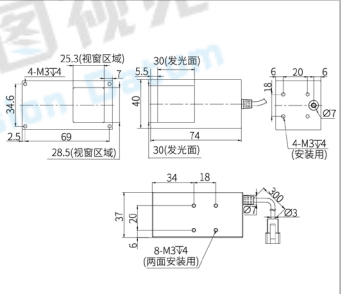
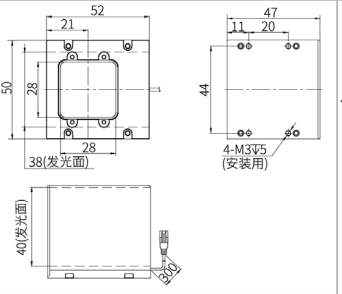
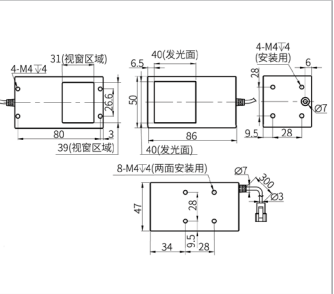
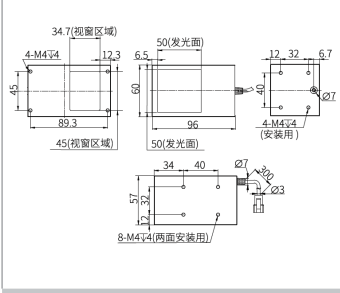
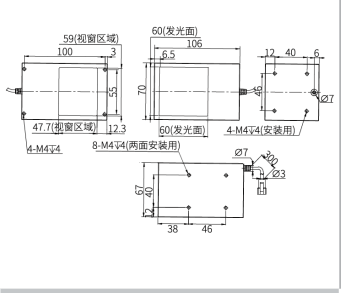
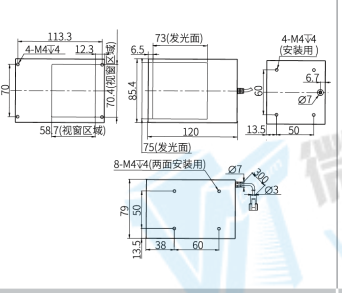
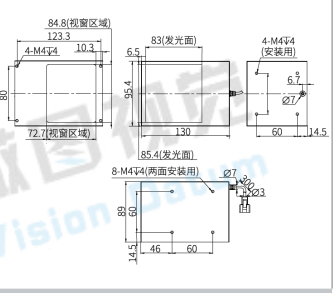
VT-LT2-C2020	VT-LT2-C3030	VT-LT2-C4038	VT-LT2-C4040
			
VT-LT2-C5050	VT-LT2-C6060	VT-LT2-C7573	VT-LT2-C8583
			
VT-LT2-C100100	VT-LT2-C120120	VT-LT2-C150120	VT-LT2-C200180
