

- 25MP @41 fps
- Adopts 10GigE interface and up to 10Gbps effective bandwidth
- Compatible with GigE Vision Protocol and the third-party software based on the protocol
- Support Windows operating platform
- Up to 1GB local memory for burst transmission and retransmission

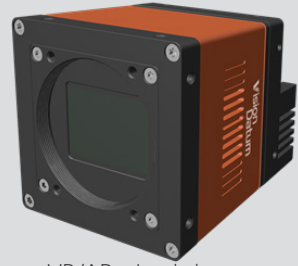

Applied range • Defect Detection • Surface Patch Detection • Visual Positioning • Size Measuring • QR Code Reading • VR/AR • Logistics

Camera	Mars25MG-41Tgm/Tgc-M58
Resolution [H*V]	5120 × 5120
Sensor	GMAX0505
Sensor Size	1.1"
Sensor Technology	Global, CMOS
Pixel Size [μm]	2.5 × 2.5
Frame Rate [fps]	41
Data Bit	12bit
Exposure Time	35us-15s
Dynamic Range	63dB
Mono/Color	Mono / Color
Image Format	Mono: Mono8/10/10Packed/12/12Packed Color: BayerRG8/10/12/10Packed/12Packed, BayerGB8/10/12/GB10Packed/GB12Packed
Interface	10 GigE
Synchronization	Via hardware trigger、software trigger or free run mode
Housing Size [l*w*h]	72.0 × 72.0 × 79 mm (600g)
Operating Temperature	-30~80 ° C (Storage), 0~50° C (Working)
Lenses Mount	M58 x 0.75, FBL 11.48±0.15
Digital I/O	Opto-isolated input x 3,opto-isolated output x 3, RS232 x 1
Power Input	DC 24V
Power Consumption	24V@<19.4 W
Driver	Mars series camera software suite or third-party GigE Vision protocol software
Operating System	Windows
Conformity	GigE Vision, GenICam

Spectral Response

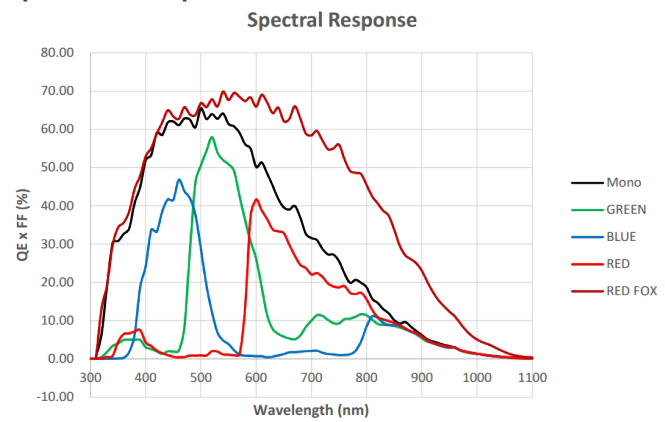

Dimensions

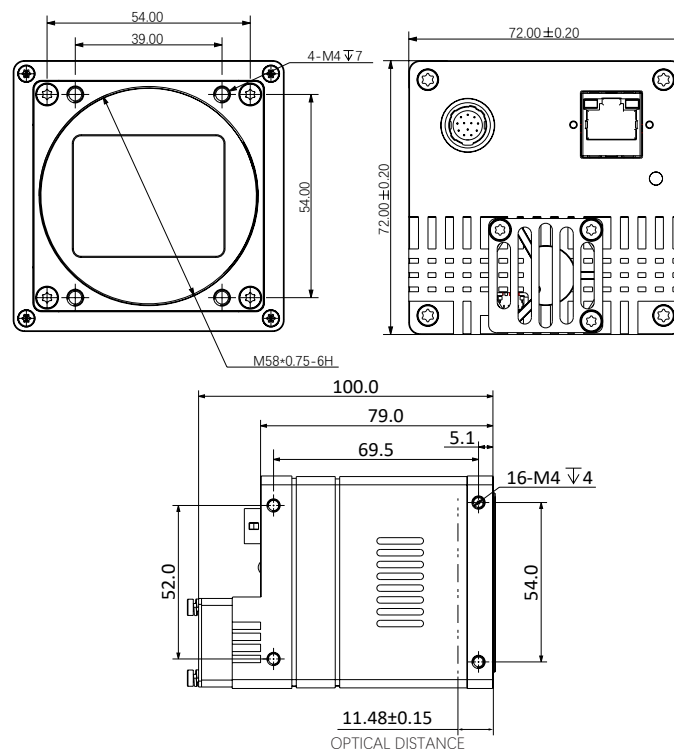

No.8, Xiyuan 9th Road West Lake District, Hangzhou 310030 China
Tel: 86-571-86888309, 86-571-86888307
Web: www.visiondatum.com Email: market@visiondatum.com

